



$$P = F/S$$

✓ **Applications**

This primary standard Range are designed to test, adjust and calibrate measuring instruments, mechanical or electronic pressure by comparison (pressure gauges, pressure transmitters or sensors or switches)

The dead weight tester consist of a pressure generator, a piston/cylinder unit, a set of weigh identified. The capstan is used to generate a pressure pushing the fluid through the piston. This pressure is balanced by the piston/cylinder assembly which allows to compare the instrument to be calibrated to the pressure values generated by the standard.

This reference instrument are used in factory or calibration laboratory. They are robust and easy to use and have a high long-term stability.

✓ **Technical specifications of the range BA1**

- **Calibration :** Our dead weight tester are calibrated under the following conditions of use :
Temperature 20°C - Pressure atmos. 1013.25 hPa - Humidity 50% - acceleration 9.80665 m/s²
In case you don't use it under the conditions mentioned above, it is necessary to recalculate the pressure generated by the dead weight according to the different variables.
- **Lubricating fluid :** Colorless mineral oil, compatible with medical or food uses - tank volume 25 cm³ - The air oil in the dead weight exchanger system / prevents contamination of the piston / cylinder.
- **Source Pressure :** Dry air - gas connection ¼ cylindrical female - This balance needs to be connected to a pressure source.
- **Check/adjust the seat :** leveling bubble and adjustable feet
- **Connecting for the instrument to be tested :** swivel G1/2 standard – other optional fittings
- **Rotating weigh :** Training masses : manual rotation
- **Crankcase :** Light alloy aluminium AG3 + high-resistance paint
- **Capstan :** removable for transport
- **Piston/cylinder :** Single piston hardened steel - **Repeatability** : 1.10⁻⁴ - **Sensitivity** : 5.10⁻⁵ - **Precision dead weight** : 10⁻³
- **Weight :** Corrosion treated steel – **total Weight** of the set of weights from 4 kg to 48 kg depending on model – Ergonomic shape of the masses, easy loading of the masses on the bell - **Marking** corresponding with the measuring unit choose (bar, mbar, KPa, PSI etc..) **Gravity** : standard (9.80665 m/s²) or local gravity without supplement
- **Operating temperature:** 18 to 28°C – 64 to 82°F

✓ **Technical product specifications**

- **Model :** BA1-60B – dead weight single piston
- **Measuring range :** 0.5 to 60 bar / 10 to 800 PSI / 50 to 6000 kPa
- **Uncertainly of the pressure measured by the DWT :** 0.002 +(1.10⁻³ x P) (with P in bar)
- **Accuracy :** 0.1% of the scale
- **Weight dead weight without weight :** 22 kg
- **Base generator :** CA1-200B
- **Typical cross-section of the piston :** 39.2280 mm²
- **Material Piston/Cylinder :** P = treated steel / C = treated steel
- **Number of piston :** 1

✓ **Various**

- **Delivery details** : a manual are provided in English or French with the device + a factory calibration certificate traceable to the national standards + data sheet + Certificate + 0.5 liter of mineral Oil
- **Maintenance** : Our technical service department is at your disposition for the revision, calibration or service your unit – Calibration device recommended every 2 or 5 years depending on your use.

✓ **Dimensions of device**

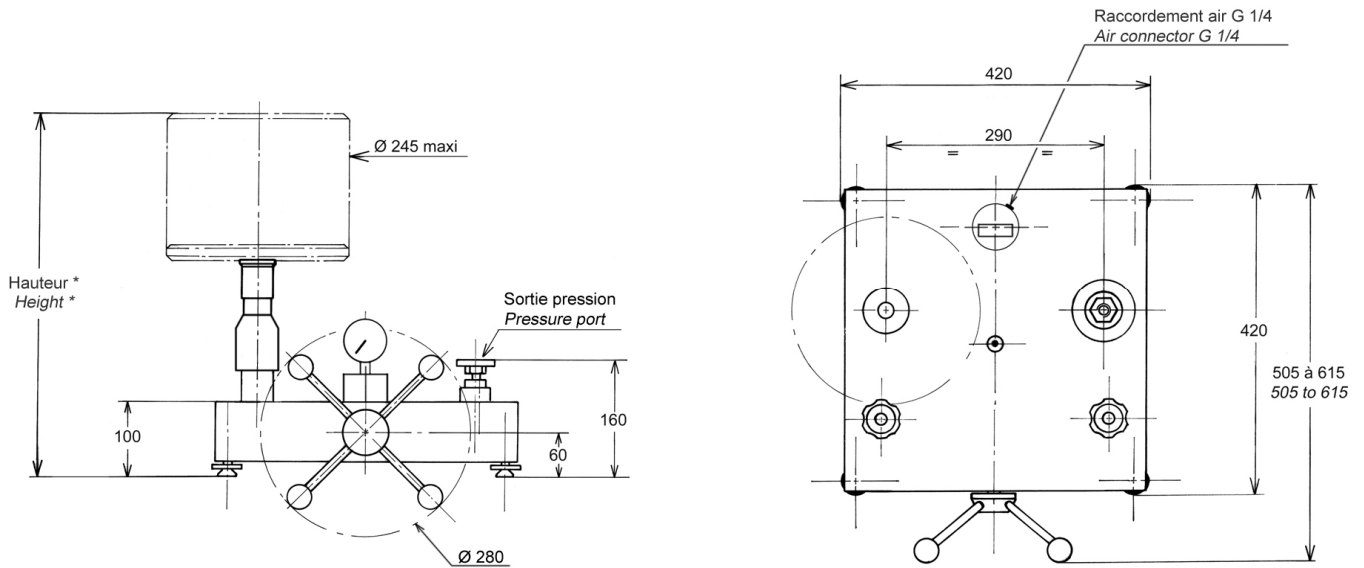

Height with standard set of weight : (bar, kPa) : 415 mm (PSI) : 395 mm

Unit used : mm

✓ **Standard weight sets and intermediate** (for other units contact us)

Standard set			
	Pressure (bar)	Total weight	Typical value (g)
Unit : BAR or Kg/cm² (Ref. MB0004)	20	2	8000
	9.5	1	3800
	5	1	2000
	2.5	1	1000
	1	2	400
	0.5	1	200
Initial Pressure bell + weight adaptation	0.5		200
TOTAL	60	8	±24 kg

Intermediate set			
	Pressure (bar)	Total weight	Typical value (g)
BAR	No set of intermediate weight		
TOTAL			

Standard set			
	Pressure (PSI)	Total weight	Typical value (g)
Unit : PSI (Ref. MB0010)	200	2	5520
	190	1	5244
	100	1	2760
	40	2	1104
	20	1	552
	10	1	276
	Initial Pressure bell + weight adaptation	10	
TOTAL	810	8	±22 kg

Intermediate set			
	Pressure (PSI)	Total weight	Typical value (g)
PSI	No set of intermediate weight		
TOTAL			

Standard set			
	Pressure (kPa)	Total weight	Typical value (g)
Unit : kPa	2000	2	8000
	950	1	3800
	500	1	2000
	250	1	1000
	100	2	400
	50	1	200
	Initial Pressure bell + weight adaptation	50	
TOTAL	6000	8	±24 kg

Intermediate set			
	Pressure (kPa)	Total weight	Typical value (g)
kPa	No set of intermediate weight		
TOTAL			

✓ **Options of the dead weight tester**

- Standard weight set additional for different units
- Certificate of calibration DAkkS or COFRAC

✓ **Suitcase for set of weight**

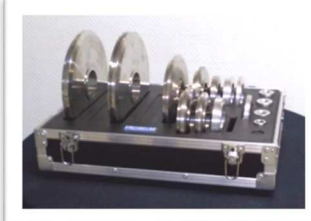
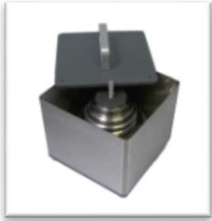

transport metal boxes

(OP0101) : 260 x 260 x 310 mm - weight empty : 6 kg

Suitcase for post planning and transportation

(OPxxxx) large : 355 x 505 x 310 mm - weight empty : 13 kg

+ (OPxxxx) small : 290 x 250 x 310 mm - weight empty : 5 kg

- **Suitcase for the dead weight (ref.OP0002) :**



✓ **Accessories** (Ask for our specific documentation)

- Accessory case (ref.OP0057)

- Setting gauge kit (ref.OP0125)

- Kit drain tank (ref.OP0025)

- Bench cleaning (ref.OP0062)

- Suitcase with pear + needle up (OP0228)



- **Connectors up to 1200 bar** : suitcase connectors M (ref.OP0174) – suitcase connectors G (ref.OP0171) - suitcase connectors NPT (ref.OP0172) - suitcase connectors BSP-TR (ref.OP0173) - suitcase with 17 connectors M + G + NPT + BSP-TR (ref.OP0037) – unit connector



✓ **Shipping and packaging**

- **Packaging** : woodpack is provided for the shipping

Designation/Reference	Dimension / carton or shipping crate	Weight empty / total weight (packaging + materiel)
Dead weight without weight	470 x 470 x 240 mm	Carton empty 1.5 kg Total weight ±20 kg
Standard weight set	300 x 300 x 170 mm	Carton empty 1.5 kg Total weight ± 27 kg
Wood packaging SB0002	790 x 480 x 340 mm	Suitcase empty 20 kg Total weight ± 70 kg (dead weight + weight set + packaging)



SB0002

- **Note** : shipping is extra.

✓ **Other models available in the range BA1**

(Datasheet are available on request or on our website : www.aremeca-instrumentation.com)

Models single piston

Models	Accuracy	Measuring range		
		Bar or kg/cm ²	PSI	kPa
BA1-120B	10 ⁻³	0.5 to 120	10 to 1600	50 to 12000
BA1-30B	10 ⁻³	0.5 to 30	10 to 400	50 to 3000
BA1-7B	10 ⁻³	0.1 to 7	1 to 100	10 to 700
BA1-1B	10 ⁻³	15 mbar to 1 bar		1.5 to 100
BA1-1VB	10 ⁻³	-15 mbar to -900 mbar		-1.5 to -90