



$$P = F/S$$

#### ✓ Applications

This primary standard Range are designed to test, adjust and calibrate measuring instruments, mechanical or electronic pressure by comparison (pressure gauges, pressure transmitters or sensors or switches)

The dead weight tester consist of a pressure generator, a piston/cylinder unit, a set of weigh identified. The capstan is used to generate a pressure pushing the fluid through the piston. This pressure is balanced by the piston/cylinder assembly which allows to compare the instrument to be calibrated to the pressure values generated by the standard.

This reference instrument are used in factory or calibration laboratory. They are robust and easy to use and have a high long-term stability.

#### ✓ Technical specifications of the range BH2

- Calibration :	Our dead weight tester are calibrated under the following conditions of use : Temperature 20°C - Pressure atmos. 1013.25 hPa - Humidity 50% - acceleration 9.80665 m/s <sup>2</sup> In case you don't use it under the conditions mentioned above, it is necessary to recalculate the pressure generated by the dead weight according to the different variables.
- Fluid :	Mineral or synthetic oil depending on model, colorless, compatible with medical or food uses – tank volume 125 cm <sup>3</sup>
- Check/adjust the seat :	leveling bubble and adjustable feet
- Connecting for the instrument to be tested :	swivel G1/2 standard – other optional fittings
- Rotating weigh :	Training masses : manual rotation
- Crankcase :	Light alloy aluminium AG3 + high-resistance paint
- Capstan :	removable for transport
- Piston/cylinder :	Single or twin piston tungsten carbide and/or treated steel - <b>Repeatability</b> : 1.10 <sup>-4</sup> - <b>Sensitivity</b> : 5.10 <sup>-5</sup> - <b>Precision dead weight</b> : 10 <sup>-4</sup>
- Weight :	stainless steel – <b>Total weight</b> of the set of weights from 25 kg to 100 kg depending on model – Ergonomic shape of the masses, easy loading of the masses on the bell - <b>Marking</b> corresponding with the measuring unit choose (bar, mbar, KPa, PSI etc..) <b>Gravity</b> : standard (9.80665 m/s <sup>2</sup> ) or local gravity without supplement
- Operating temperature:	18 to 28°C – 64 to 82°F

#### ✓ Technical product specifications

- Model :	BH2-7000B - dead weight single piston
- Measuring range :	200 to 7000 bar / 2000 to 100000 PSI / 20000 to 700000 kPa
- Uncertainty of the pressure measured by the DWT :	0.1 + (5.10 <sup>-4</sup> x P) (with P in bar)
- Accuracy :	0.05% of the scale
- Weight dead weight without masses :	22 kg
- Base generator :	CH2-7000B
- Fluid :	Oil Sebacate - fluid density : 915 kg/m <sup>3</sup>
- Typical cross-section of the piston :	0.5026 mm <sup>2</sup>
- Material Piston/Cylinder :	P = tungsten carbide / C = tungsten carbide
- Number of piston :	1

✓ **Various**

- **Delivery details** : a manual are provided in English or French with the device + a factory calibration certificate traceable to the national standards + data sheet +Certificate + 0.5 liter of mineral Oil
- **Maintenance** : Our technical service department is at your disposition for the revision, calibration or service your unit – Calibration device recommended every 2 or 5 years depending on your use.

✓ **Dimensions of device**

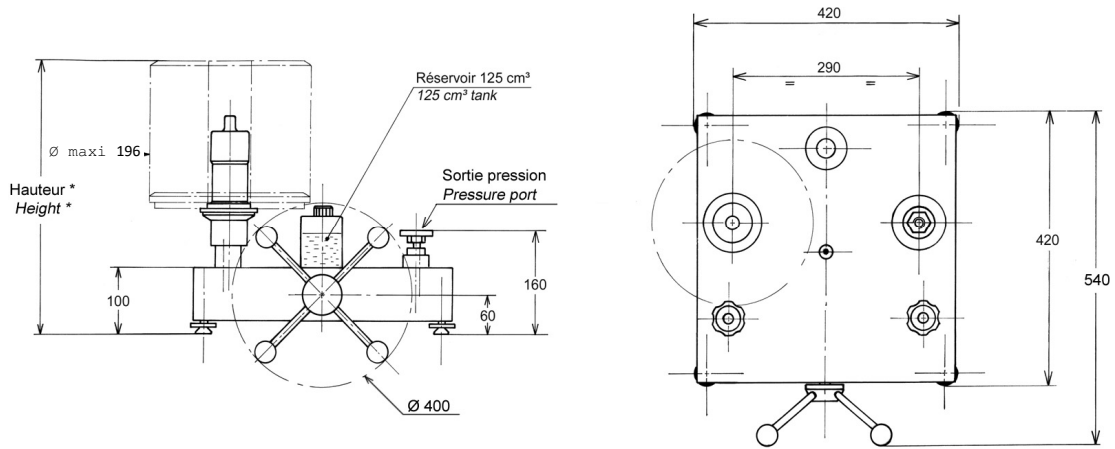

Height with standard set of weight : (bar, KPa) : 450 mm

(PSI) : 000 mm

Unit used : mm

✓ **Standard weight sets and intermediate**

Standard set			
	Pressure (bar)	Total weight	Typical value (g)
<b>Unit : BAR or kg/cm<sup>2</sup></b> (Ref. MB0000)	1000	5	4000
	800	1	3200
	400	1	1600
	200	2	800
	100	2	400
	50	1	200
Pressure Weight bell + adaptation weight	200		800
<b>TOTAL</b>	<b>7050</b>	<b>12</b>	<b>± 28 kg</b>

Intermediate set in option			
	Pressure (bar)	Total weight	Typical value (g)
<b>BAR or kg/cm<sup>2</sup></b> (Ref. MB0000)	40	1	160
	20	1	80
	10	1	40
	4	2	16
	2	1	8
	1	1	4
<b>TOTAL</b>	<b>81</b>	<b>7</b>	<b>324 g</b>

Standard set			
	Pressure (PSI)	Total weight	Typical value (g)
<b>Unit : PSI</b> (Ref. MB0000)	20000	3	5520
	18000	1	4968
	10000	1	2760
	4000	2	1104
	2000	1	552
	1000	1	276
Pressure Weight bell	2000		551
<b>TOTAL</b>	<b>101000</b>	<b>9</b>	<b>±26 kg</b>

Intermediate set in option			
	Pressure (PSI)	Total weight	Typical value (g)
<b>PSI</b> (Ref. MB0000)	400	1	110.4
	200	2	55.2
	100	1	27.6
	40	2	11
	20	1	5.5
	10	1	2.75
<b>TOTAL</b>	<b>1010</b>	<b>8</b>	<b>278.65 g</b>

Standard set			
	Pressure (Kpa)	Total weight	Typical value (g)
<b>Unit : kPa</b>	100000	5	4000
	80000	1	3200
	40000	1	1600
	20000	2	800
	10000	2	400
	5000	1	200
Pressure Weight bell + adaptation weight	20000		800
<b>TOTAL</b>	<b>705000</b>	<b>12</b>	<b>± 28 kg</b>

Intermediate set in option			
	Pressure (Kpa)	Total weight	Typical value (g)
<b>kPa</b>	4000	1	160
	2000	1	80
	1000	1	40
	400	2	16
	200	1	8
	100	1	4
<b>TOTAL</b>	<b>8100</b>	<b>7</b>	<b>324 g</b>

Other units are available on request

✓ **Options of the dead weight tester**

---

- intermediate weight set or Standard weight set additional for different units
- Calibration of the instrument : Points statement AREMECA or certificate of calibration DAkkS or COFRAC
- Tin oil : 1 liter, 2 liters or 5 liters of oil
- Kit Motorization (driving of masses in rotation) / Visualization (position of the piston by indicator lights) (-> BH3)
- Calculator module with dynamic display of the piston position, automatic display of the pressures generated by the scale as a function of temperature, atmospheric pressure and hygrometry, with transfer of data to a computer for total traceability and calibration certificate edition. (-> BH4)

✓ **Suitcase for set of weight**

---

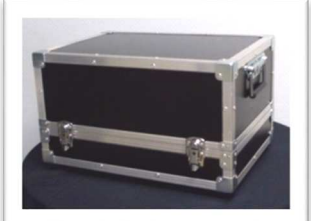
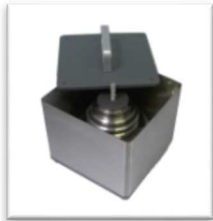

transport metal boxes

(OP0101) : 260 x 260 x 310 mm - weight empty : 6 kg

Suitcase for post planning and transportation

(OPxxxx) large : 355 x 505 x 310 mm - weight empty : 13 kg  
+ (OPxxxx) small : 290 x 250 x 310 mm - weight empty : 5 kg

- **Suitcase for the dead weight (ref.OP0002) :**



✓ **Accessories** (Ask for our specific documentation)

---

- Accessory case (ref.OP0057)
- Setting gauge kit (ref.OP0125)
- Kit drain tank (ref.OP0025)
- Separator all fluids up to 800 bar (ref.OP0023)
- Bench cleaning (ref.OP0062)
- Suitcase with pear + needle up (OP0228)



- **Connectors up to 1200 bar** : suitcase connectors M (ref.OP0174) – suitcase connectors G (ref.OP0171) - suitcase connectors NPT (ref.OP0172) - suitcase connectors BSP-TR (ref.OP0173) - suitcase with 17 connectors M + G + NPT + BSP-TR (ref.OP0037) – unit connector
- **Connectors 2000 bar** : suitcase connectors HP (ref.OP0220) with M16x150 + M20x150 + 9/16UNF-18 M/M + G1/2 + 9/16UNF-18 M/F



✓ **Transport and packaging**

- **Packaging** : woodpack is provided for the shipping

Designation/Reference	Dimension / carton or shipping crate	Weight empty / total weight (packaging + materiel)
<b>Dead weight without weight</b>	470 x 470 x 240 mm	Carton empty 1.5 kg Total weight ±24 kg
<b>Standard weight set</b>	300 x 300 x 170 mm	Carton empty 1.5 kg Total weight ±30 kg
<b>Wood packaging SB0002</b>	790 x 480 x 340 mm	Suitcase empty 20 kg Total weight ±74 kg (dead weight + weight set + packaging)



SB0002

- **Note** : shipping is extra.

✓ **Other models available in the range BH2**

(Datasheet is available on request or on our website : [www.aremeca-instrumentation.com](http://www.aremeca-instrumentation.com))

Models single piston

Models	Accuracy	Measuring range		
		Bar ou kg/cm²	PSI	kPa
BH2-4000B	10 <sup>-4</sup>	40 to 4000	600 to 60000	4000 to 400000
BH2-3000B	10 <sup>-4</sup>	40 to 3000	600 to 44000	4000 to 300000
BH2-2500B	10 <sup>-4</sup>	40 to 2500	600 to 36200	4000 to 250000
BH2-2000B	10 <sup>-4</sup>	40 to 2000	600 to 30000	4000 to 200000
BH2-1200B sp	10 <sup>-4</sup>	2 to 1200	30 to 16000	200 to 120000
BH2-600B sp	10 <sup>-4</sup>	2 to 600	30 to 10000	200 to 60000
BH2-300B sp	10 <sup>-4</sup>	1 to 300	15 to 4000	100 to 30000
BH2-150B	10 <sup>-4</sup>	0.5 to 150	10 to 2000	50 to 15000
BH2-60B	10 <sup>-4</sup>	0.2 to 60	3 to 800	20 to 6000
BH2-30B	10 <sup>-4</sup>	0.1 to 30	2 to 400	10 to 3000

Dual piston models : these dead weight tester integrating two pistons can get two ranges from a single set of weight

Models	Accuracy	Measuring range		
		Bar ou kg/cm²	PSI	kPa
BH2-1200B dp	10 <sup>-4</sup>	1 to 60 + 20 to 1200	10 to 800 + 200 to 16000	100 to 6000 2000 to 120000
BH2-600B dp	10 <sup>-4</sup>	1 to 60 + 10 to 600	10 to 800 + 100 to 8000	100 to 6000 1000 to 60000
BH2-300B dp	10 <sup>-4</sup>	1 to 60 + 5 to 300	10 to 800 + 50 to 4000	100 to 6000 500 to 30000