



#### ✓ Applications

The range of compressors is designed to test, adjust and calibrate measuring instruments mechanical or electronic pressure by comparison (pressure gauges, pressure transmitters or sensors or switches).

These generators are equipped with a pressure tank visible level, two valves connected by a set of two-stage variable volumes. The capstan can generate the pressure pushing the fluid through the variable volumes to fittings provided for receiving the pressure instruments.

These compressors are designed for industry or laboratory. They are robust and easy to use and have a very high long-term stability.

They have the opportunity to grow in dead weight tester by simply adding a kit with : a set piezometric and a set of weights

#### ✓ Technical specifications of the range CH2

- Fluid :	Mineral oil or synthetic oil depending on the model colorless compatible with medical or food uses
- Tank :	125 cm <sup>3</sup>
- Volume de fluid expelled :	61 cm <sup>3</sup>
- Check/adjust the seat :	leveling bubble and adjustable feet
- Connection for the instrument to be tested :	swivel G1/2 standard – other optional fittings
- Carter :	Light alloy aluminium AG3 + high-resistance paint
- Capstan :	Removable for transport
- Operating temperature:	18 to 28°C – 64 to 82°F

#### ✓ Technical product specifications

- Model :	CH2-4000B
- Measuring range :	0 to 4000 bar / 0 to 60000 PSI / 0 to 400000 kPa
- Sensitivity :	10% Pmaxi = 0.2 bar / 50% Pmaxi = 1 bar / 100% Pmaxi = 2 bar
- Weight comparator :	18 kg
- Fluid :	Oil Sébacate - fluid density : 915 kg/m <sup>3</sup>
- Section of the pistons :	low pressure = 7 cm <sup>2</sup> / High pressure = 0.2cm <sup>2</sup>
- Number of piston :	2
- Material Piston/Cylinder :	P:BP = stainless steel + carbide tungstene / C = dtainless steel + treated steel
- Piping :	copper + polyamide + stainless steel

#### ✓ Divers

- **Delivery details** : a manual are provided in English or French with the device + data sheet + Certificate + 0.5 liter of mineral Oil
- **Maintenance** : Our technical service department is at your disposition for the revision, calibration or after sales service your unit – Calibration device recommended every 2 or 5 years depending on your use.

✓ **Dimensions of device**

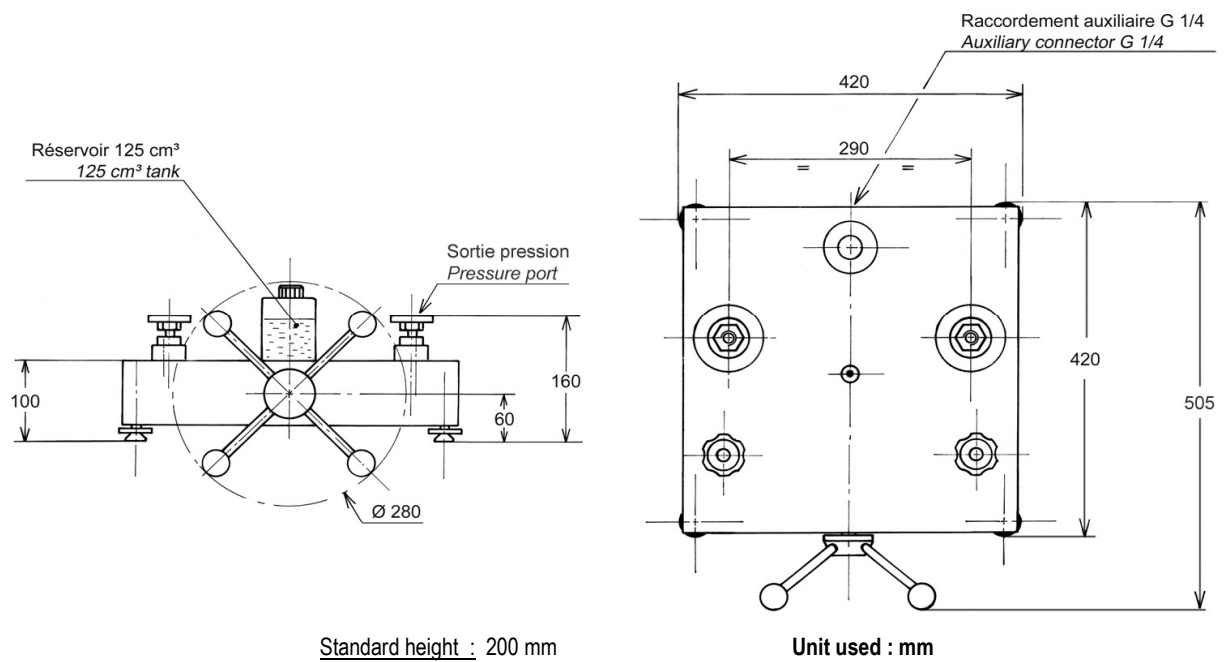

✓ **Options of the generator**

- Kit for dead weight (CH2 -> BH2)
- Pump hands with tank (Ref. OP0158)
- Pressure microajusteur : increases the accuracy (contact us)
- adaptation corrosives fluid (skydroll, brake fluid)
- Oil H15 : 1 liter (ref.OP0013) or 5 liters (ref.OP0010)
- Suitcase for the geenerator (ref.OP0002) :



✓ **Accessories** (ask us our specific documentation)

- **Connectors up to 1200 bar** : suitcase connectors M (ref.OP0174) – suitcase connectors G (ref.OP0171) - suitcase connectors NPT (ref.OP0172) - suitcase connectors BSP-TR (ref.OP0173) - suitcase with 17 connectors M + G + NPT + BSP-TR (ref.OP0037) – unit connector
- **Connectors 2000 bar** : suitcase connectors HP (ref.OP0220) with M16x150 + M20x150 + 9/16UNF-18 M/M + G1/2 + 9/16UNF-18 M/F



- Accessory case (ref.OP0057)
- Setting gauge kit (ref.OP0125)
- Kit drain tank (ref.OP0025)
- Separator all fluids up to 800 bar (ref.OP0023)
- Bench cleaning (ref.OP0062)
- Suitcase with pear + needle up (OP0228)



✓ **Transport and packaging**

- **Packaging** : pack is provide for the shipping

Designation/Reference	Dimension / carton or shipping crate	Weight empty / total weight (packaging + device)
<b>Compressor</b>	470 x 470 x 240 mm	Carton empty 1.5 kg Total weight ±20 kg
<b>packaging</b> SB0001	480 x 480 x 340 mm	Box empty 10 kg Total weight ±30 kg (comparator + packaging)



SB0001

- **Note** : shipping and taxes are your responsibility - EX-Works Vendôme (France)

✓ **Other models available in the range CH2**

(Datasheet is available on request or on our website : [www.aremeca-instrumentation.com](http://www.aremeca-instrumentation.com))

Models	Measuring range		
	Bar or kg/cm <sup>2</sup>	PSI	kPa
CH2-7000B	0 to 7000	0 to 101000	0 to 700000
CH2-2000B	0 to 2000	0 to 29000	0 to 200000
CH2-1250B	0 to 1250	0 to 18000	0 to 125000
CH2-125B	0 to 125	0 to 1800	0 to 1250