



✓ **Applications**

The range of compressors is designed to test, adjust and calibrate measuring instruments mechanical or electronic pressure compared to a standard

They consist of a pool of oil sight gauge connected to a piston / cylinder unit. The capstan can generate a pressure by compressing the fluid through the piston. Two connectors are provided for receiving the instruments compared.

These compressors are designed to pressure the relative calibration. They are robust and easy to use and have the opportunity to grow in dead weight tester by simply adding a kit comprising: piezometric and a set of weights.

✓ **Technical specifications of the range CA1**

- Fluid : clean, dry air type compressed air or azote
- Volume de fluid expelled : 15 cm³
- Check/adjust the seat : leveling bubble and adjustable feet
- Connection for the instrument to be tested : swivel G1/2 standard – other optional fittings
- Carter : Light alloy aluminium AG3 + high-resistance paint
- Capstan : Removable for transport - moving axis
- Operating temperature: 18 to 28°C – 64 to 82°F

✓ **Technical product specifications**

- Model : CA1-200B
- Measuring range : 0 to 200 bar / 0 to 3000 PSI / 0 to 20000 kPa
- Sensitivity : 10% Pmaxi = 0.001 bar / 50% Pmaxi = 0.002 bar / 100% Pmaxi = 0.005 bar
- Weight comparator : 18 kg
- Section of the piston : low pressure = 1.8 cm²
- Number of piston : 1
- Material Piston/Cylinder : P = stainless steel / C = Aluminium
- Piping : copper

✓ **Divers**

- **Manuel** : a detailed operating instructions supplied with the device + Certificate
- **Maintenance** : Our technical department is at your disposition for the revision, calibration or service your unit – Calibration device recommended every 2 years.

✓ **Dimensions of device**

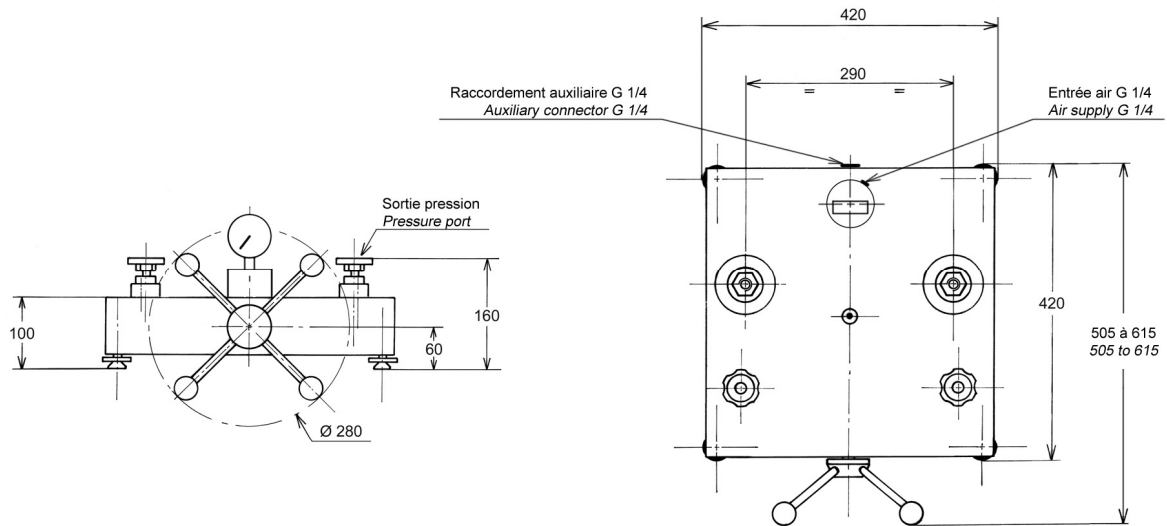

Unit used : mm

✓ **Options of the generator**

- Kit for dead weight (CA1 -> BA1)
- Suitcase for the generator (ref.OP0002) :



✓ **Accessories** (ask us our specific documentation)

- Connectors up to 1200 bar : suitcase connectors M (ref.OP0174) – suitcase connectors G (ref.OP0171) - suitcase connectors NPT (ref.OP0172) - suitcase connectors BSP-TR (ref.OP0173) - suitcase with 17 connectors M + G + NPT + BSP-TR (ref.OP0037) – unit connector



- Accessory case (ref.OP0057)
- Setting gauge kit (ref.OP0125)
- Separator all fluids up to 800 bar (ref.OP0023)
- Bench cleaning (ref.OP0062)
- Suitcase with pear + needle up (OP0228)



✓ **Transport and packaging**

- **Packaging** : pack is provide for the shipping

Designation/Reference	Dimension / carton or shipping crate	Weight empty / total weight (packaging + device)
Compressor	470 x 470 x 240 mm	Carton empty 1.5 kg Total weight ±20 kg
packaging SB0001	480 x 480 x 340 mm	Box empty 10 kg Total weight ±30 kg (comparator + packaging)



SB0001

- **Note** : shipping and taxes are your responsibility - EX-Works Vendôme (France)

✓ **Other models available in the range CA1**

(Datasheet is available on request or on our website : www.aremeca-instrumentation.com)

Models	Measuring range		
	Bar or kg/cm ²	PSI	KPa